

# ALPHA 650x850 HEATED TOWEL RACK

## ASTALPHA650

### Specification

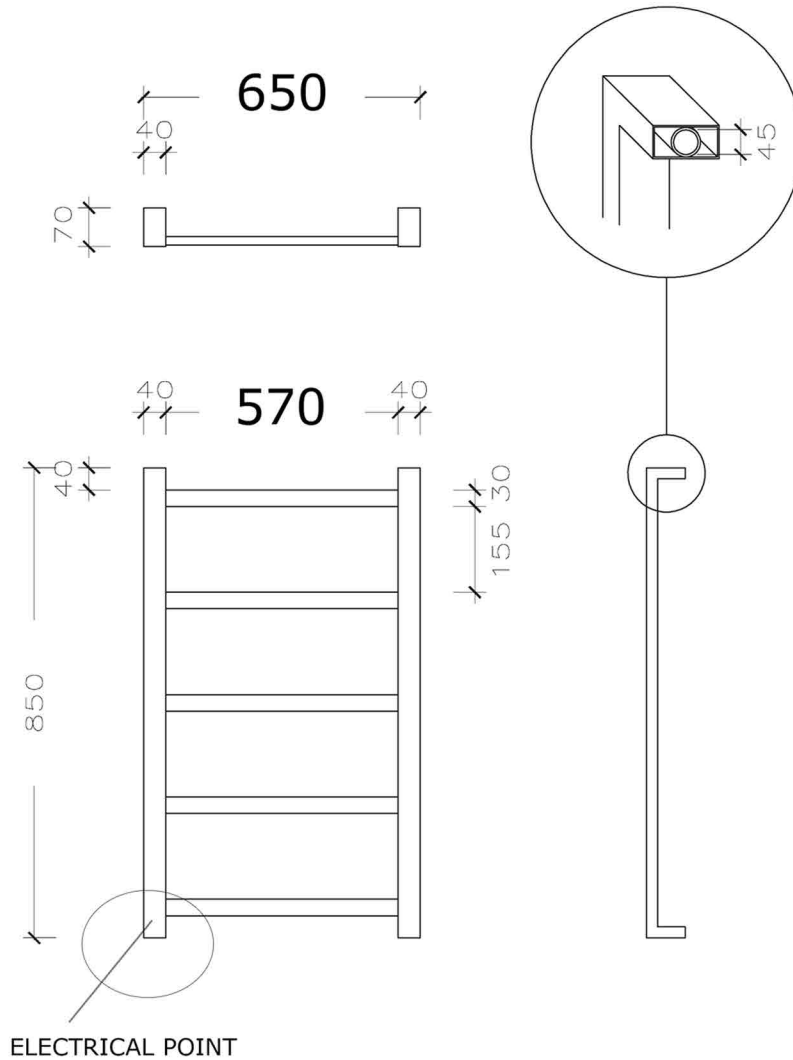

- 240v
- incorporated double insulated electric heating element (fully earthed)
- 304 stainless steel
- Concealed left cable entry
- 5 year warranty
- Full compliance with IEC 60529:2001 - IP44 rating
- Full compliance with AS/NZS 60335.2.43:2005

[www.casaitaliana.co.nz](http://www.casaitaliana.co.nz)

[info@casaitaliana.co.nz](mailto:info@casaitaliana.co.nz)

Please contact your nearest show room for more information

ca  
sa | ITALIANA