

# ALPHA 600x1500 HEATED TOWEL RACK

## ASTALPHA600

### Specification

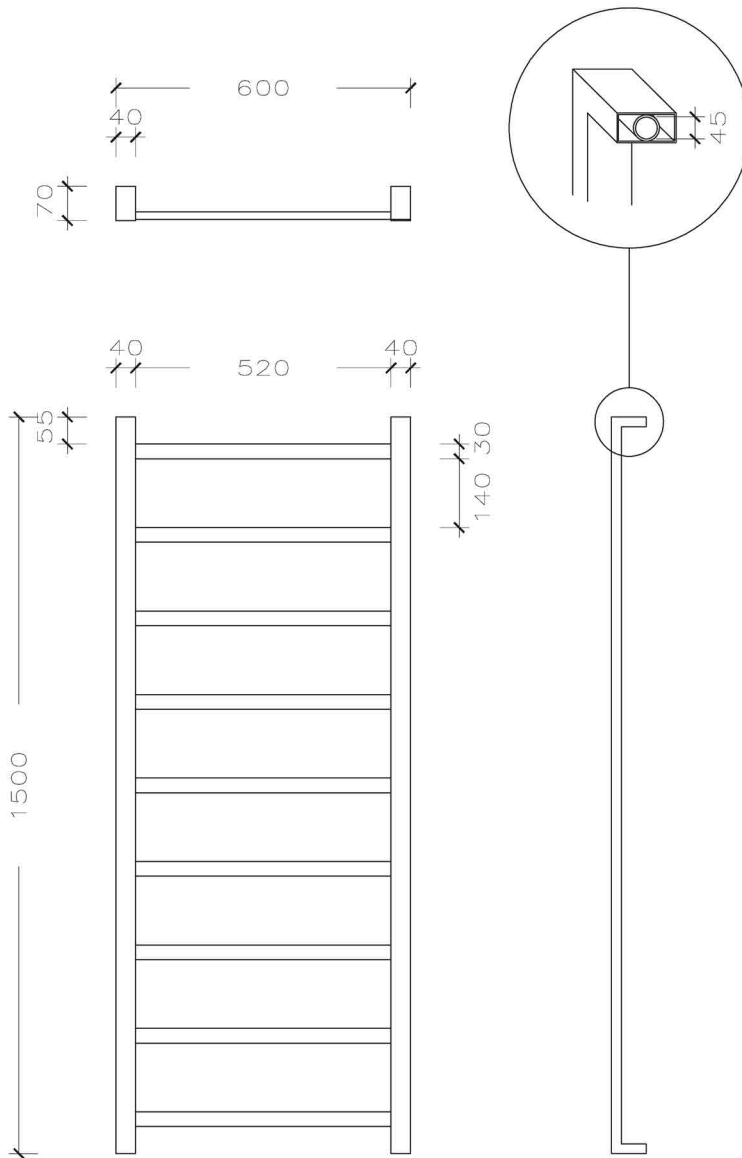

ALPHA 600 X 1500

- 240v
- incorporated double insulated electric heating element (fully earthed)
- 304 stainless steel
- Concealed left cable entry
- 5 year warranty
- Full compliance with IEC 60529:2001 - IP44 rating
- Full compliance with AS/NZS 60335.2.43:2005

[www.casaitaliana.co.nz](http://www.casaitaliana.co.nz)

[info@casaitaliana.co.nz](mailto:info@casaitaliana.co.nz)

Please contact your nearest show room for more information



ca  
sa | ITALIANA